

SHAKER CONVEYORS

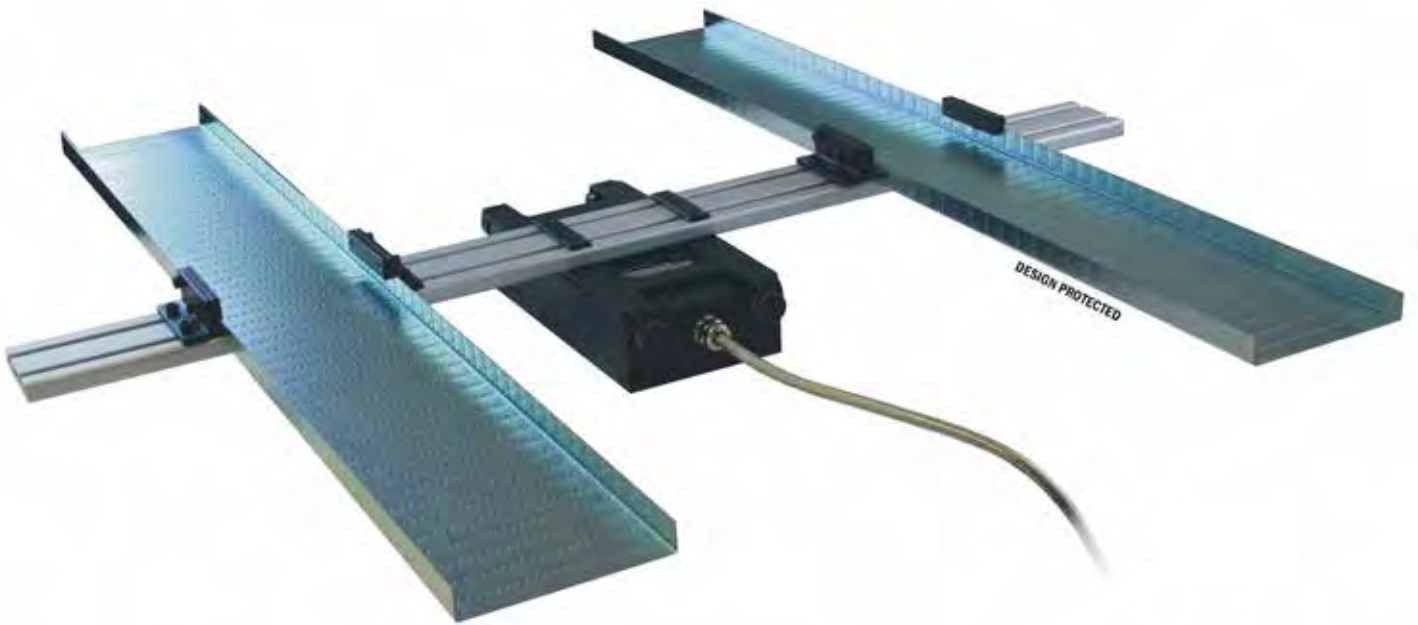

CLEAN ELECTRICAL ENGINEERING - INSTALL AND FORGET

With a transporter from AluFlex you will get the most revolutionary and state-of-the-art among transporters. The AluFlex transporter is the cleanest and most maintenance free shaker conveyor on the market.

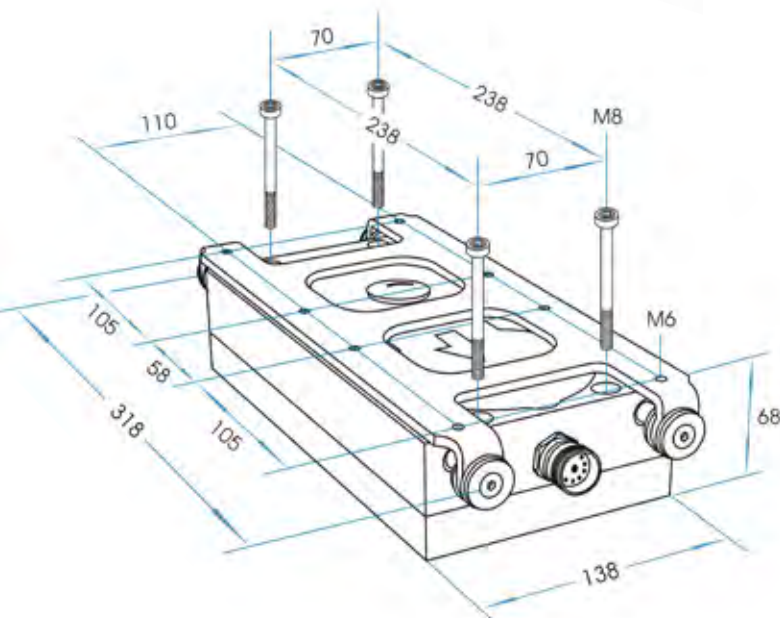

CLEAN

AluFlex uses the latest, state-of-the-art technology. The electric feeders are extremely clean without any form of emissions (e.g. oil mist) and are an excellent replacement for pneumatic transporters. The cleanliness is what makes our electric shaker conveyor unique. Clean Line 121 (IP66) can be used in many sectors that previously have been restricted to belt or vibratory conveyors. Pharmaceutical and food industry will now be able to easily replace older conveyor systems with a more cost efficient solution. The electric conveyor is designed to be environmental friendly. The working environment is considerably enhanced and the transported goods is not affected by air born emissions. Transporters from AluFlex fully comply with the industries forthcoming environmental requirements – they are an investment for the future.

SILENT

The electric conveyor is very silent, only 60 dB (A). All mechanical parts are self-contained and working in a closed oil bath. The minimal noise enhances the working environment significantly, since our electric conveyor stands in its own class compared to pneumatic and vibratory conveyors.

MAINTENANCE-FREE

The AluFlex transporter is designed for continuous operation and a long and maintenance free service life. There is only one moving outer part – to be compared with the numerous moving parts in a conveyor belt system! No belt to change, no outer part to lubricate and the metallic tray is easy to clean. Maintenance costs are eliminated.

ENERGY EFFICIENT

Due to the electric powering and a very limited inner friction, the electric transporter from AluFlex consumes only 5% of the energy that a pneumatic transporter uses. The advanced sensor-controlled motor makes sure that no more energy is used than what is needed for the actual workload.

COMPACT

AluFlex offers real small state of the art electric friction feeders. ECS-121 (our biggest product) is only 68 mm high, 138 mm wide and 318 mm long which makes it unique in the world. It's easy to apply in connection with presses and can easily be fitted into machine tools and producing machines.

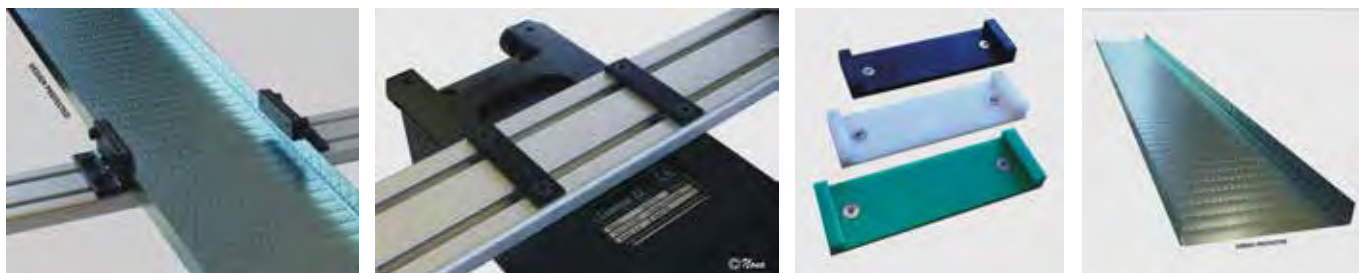

ADJUSTABLE SPEED

The mechanical continuous speed adjustment allows you to easily adjust the feeder to focus on strength or speed according to the material you want to move. The sensor-controlled technology generates 200% more power in the start-up phase, which means a loaded tray will not cause any problems.

UNIQUE MOVEMENT

The unique movement distribute and spread the material while transporting it. The AluFlex shakers straight linear movement handles the material more gently than traditional vibrators, to the extent that the tray may even be made of glass. The unique movement moves lightweight particles and heavier materials with the same speed.

ADJUSTED TO PICK & PLACE ROBOTS / VISION

The unique movement spreads the transported material and separates the details, making it easier for pick and place robots. The tray can be manufactured in a transparent material (glass/lexan) for see-through and vision systems where you can see all items from beneath.

STRONG

The transporter is very strong from the start, due to its sensor controlled technology. During the starting up, 200% more power is generated, which means the tray can be loaded without causing problems.

RELIABLE

Motor protection and a built in motion sensor ensures the complete functioning in all shake transporters from AluFlex. Downtime due to malfunctioning can be very costly. In case of malfunctioning the transporter immediately sends a warning via the M12 universal contact. This can stop the whole production line, if you wish. No need for external sensors. The built-in ball bearing mechanism can withstand very high stress and has a long lifetime. In short, an electromechanical shake transporter from AluFlex is extremely reliable, which makes it your obvious choice.

FLEXIBLE POWER CONNECTION

The electric transporter from AluFlex is available in 110-230 V, 50-60 Hz, 1-phase AC, easily connected to the power grid, or in a 24 VDC version.

COMPLETE

An electric transporter from AluFlex is a complete product, delivered with installation drawings and fasteners for transporter and tray. We can provide accessories like a well-designed feeding system with bars, fasteners and sliding parts, plus trays made of specially designed structured sheet metal. Trays can be custom ordered in many different materials, including non-stick coating, and lengths and widths adjusted to your specific needs. The adjustable bar system also allows you to mount multiple trays on one feeder. We offer free technical support.

EASY TO INSTALL / 3D

The transporter is easily fastened to the machine tool or production equipment with the four clamping bolts. The feeding tray is easily mounted on the feeder with the accompanying fasteners. Connect to power supply – ready to go! You can download drawings in 3D format on www.aluflex.com



TECHNICAL DATA

Max distributed load	30 kg
Max weight for shaking chute / plate	6 kg
Stroke	20 mm
Feeding speed (mechanically adjustable)	4-8 m/min
Sensor controlled shutdown warning	by M12 connector
Start/Stop function	can be controlled by M12 connector
Motor and overload protection	built-in
Noise level	60 dB (A)
Energy consumption	0,1 kW
Electricity	110-230 VAC, 50-60 Hz or 24 VDC
Dimensions (LxWxH)	318x138x68 mm
Protection class (only Clean Line)	IP66
Weight	6,3 kg

WORLDS SMALLEST ULTRA COMPACT ELECTRIC SHAKER CONVEYOR

ECS-141 and Clean Line 141

Unique Installation Height Only 47 mm



IP66

TECHNICAL DATA

Max distributed load	15 kg
Max weight for tray	4 kg
Stroke	20 mm
Feeding speed (mechanical adjustable)	4-8 m/min

The unit is delivered set to maximum speed. The speed may be reduced to increase the load capacity.

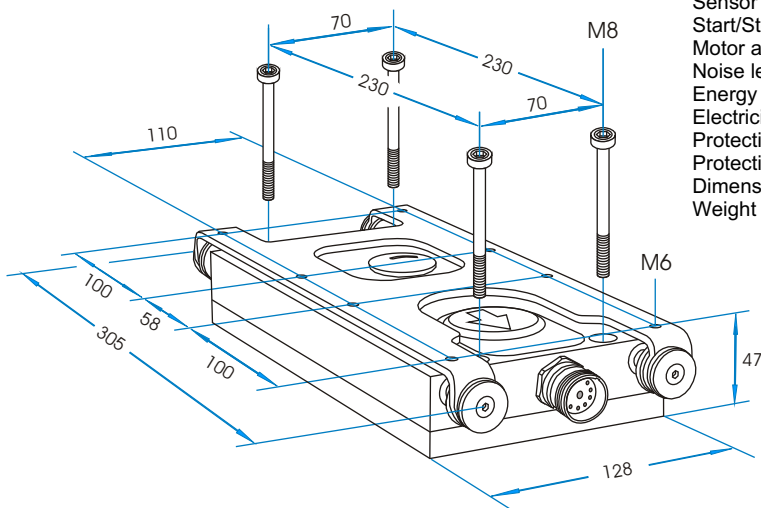

Sensor controlled shutdown warning	by M12 connector
Start/Stop function can be controlled	by M12 connector
Motor and overload protection	built-in
Noise level	60 dB (A)
Energy consumption	0,07 kW
Electricity	110-230 VAC, 50-60 Hz or 24 VDC
Protection class ECS-141	IP62
Protection class Clean Line 141	IP66
Dimensions (LxWxH)	305x128x47 mm
Weight	3,7 kg



Your Partner in Automation Solutions



Item Aluminium profiles



D30 Tube System



Work Bench System

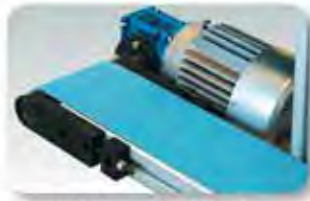

Belt Conveyor System



Palette Conveyor System



Lean Production System



Item News Every Year



Ball Bushings



Rack and Pinion System



Compact Rail



Linear Guides



Ball Screws



Easy Rail



Heavy Telescopic Rail



Light Telescopic Rail



Servo Motors



Linear Modules



Complete Solutions

AluFlexGroup

YOUR PARTNER IN AUTOMATION SOLUTIONS

AluFlex AB | item profiili oy | LinearModul A/S | AluFlex System AS

AluFlex AB
Lilla Garnisonsgatan 34
254 67 Helsingborg
Tel +46 42 38 02 30
Fax +46 42 38 02 31
orders@aluflex.se
www.aluflex.se

LinearModul A/S
Sivlandvænget 13 B
5260 Odense S
Tel +45 65 91 72 10
Fax +45 65 91 72 20
orders@linearmodul.dk
www.linearmodul.dk

AluFlex System AS
Energivegen 14
Postboks 428
2051 Jessheim
Tlf +47 63 94 49 20
Faks +47 63 94 49 21
orders@aluflex.no
www.aluflex.no

item profiili oy
Sienitie 27
00760 Helsinki
Puh +358 9 854 56 50
Fax +358 9 854 56 544
orders@itemprofiili.fi
www.itemprofiili.fi

www.aluflex.com